



DYKLOMME TIL TERMOMETER SERIE 52

Serie SWT52

SWT52G-3907317

Dyklus med gevind messing 45mm G1/2B" 10x8mm

- Omkostningseffektivt design
- Med gevind eller til indsvejsning
- Anvendes i temperaturer op til 500°C
- Kobberlegering, ST35 eller rustfrit stål som materiale
- Op til 200mm indstikslængde



PRODUKTBESKRIVELSE

SPECIFIKATIONER

Diameter	10 mm
Indstikslængde	45 mm
Inside diameter	8 mm
Materiale	Kobberlegering
Temperaturområde til	160 °C
Trykområde max	6 bar

Dimensions in mm

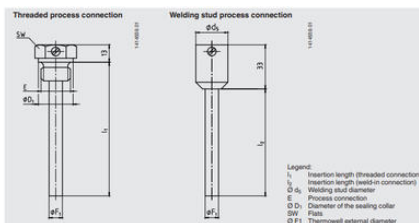

Threaded process connection (Copper alloy, St35 or stainless steel)

Thermometer	Dimensions in mm				
	l_1	E	SW	$\varnothing F_1$	$\varnothing D_1$
Model 52	45	G 1/2 B	27	10	26
	63	G 1/2 B	27	10	26
	100	G 1/2 B	27	10	26
	160	G 1/2 B	27	10	26
	200	G 1/2 B	27	10	26

Welding stud process connection (St35 or stainless steel)

Thermometer	Dimensions in mm		
	l_2	$\varnothing d_5$	$\varnothing F_1$
Model 52	43	24	10
	80	24	10
	140	24	10
	180	24	10

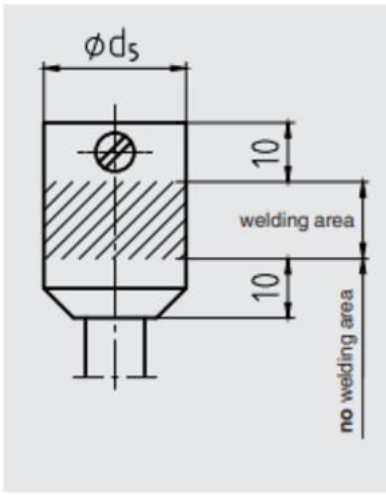

Process connection	Insertion length, l_i , of the thermometer
Thread	l_i = insertion length, l_i , of the thermowell
Welding stud	l_i = insertion length, l_i , of the thermowell + 20 mm [0.8 in]